

Product Information

FIMUSPMAIN - Spin Maracas Musical Insert

BS EN 1176 - Designed to British & European Standards

MATERIALS

Panels - Two Colour **XDeco** High Density Polyethylene (HDPE)

Maracas - High Density Polyethylene (HDPE)

SUPPLY METHOD

Insert- Assembled

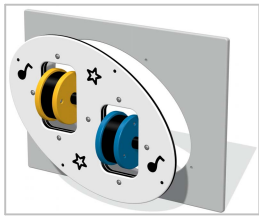
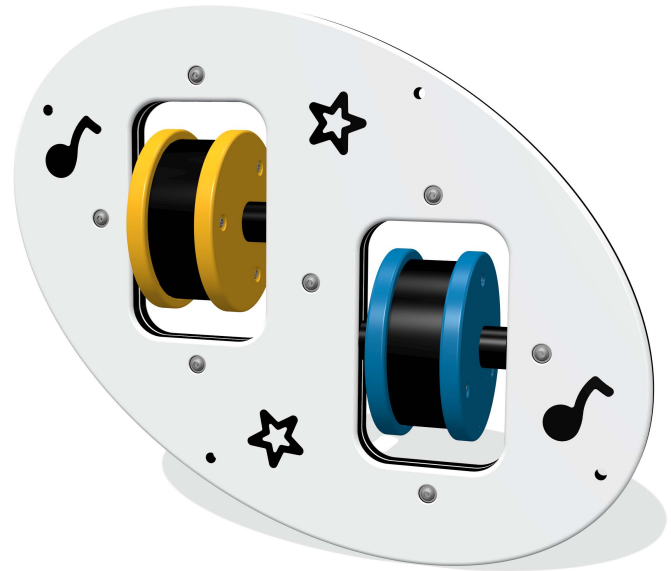

Insert can easily attach to your own panel



Rear view of insert attached to host panel

DIMENSIONS

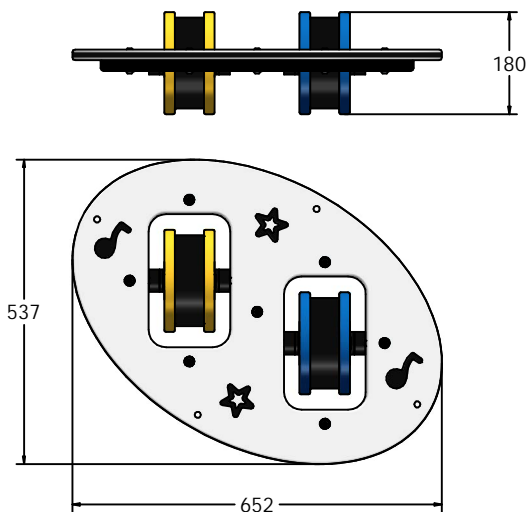

Host panel fixing detail

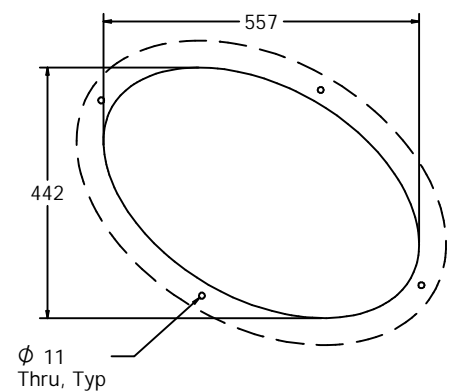

CAD available on request

TECHNICAL

Age Range: 2+ Years
Largest Part: 652 x 537 x 180mm
Total Weight: 6kg Approx
Surfacing: N/A

IMPORTANT: you must specify the colour option you require at the time of order if it is different from the colour listed/shown above, requirements are subject to availability at the time of order