

Product Information

FIFTRT01 - Ribbed Tunnel - 1m

BS EN 1176 - Designed to British & European Standards

MATERIALS

Panels - Two Colour High Density Polyethylene (HDPE)

Steel Legs - Mild steel legs with galvanised finish

Ribbed Tunnel - HDPE Heavy duty ribbed tunnel with a smooth inner

SUPPLY METHOD

Tunnel - Fully assembled

Legs - Supplied with fixings needed to attach to tunnel

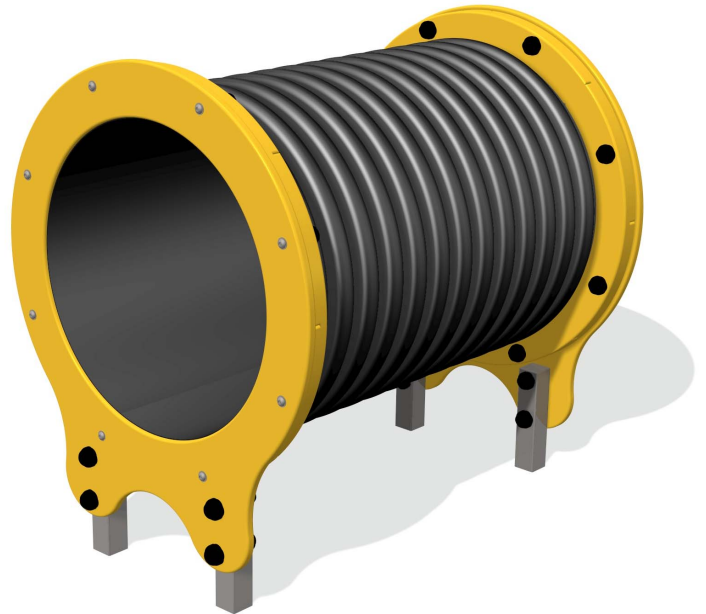

DIMENSIONS

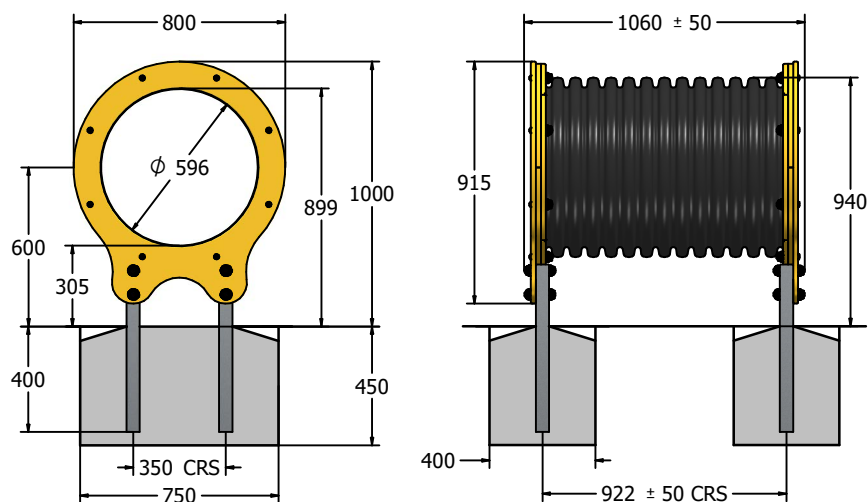

TECHNICAL

Age Range: 2+ Years
Largest Part: Tunnel Assembly - 800 x 915 x 1060 ± 50mm
Total Weight: 85.5kg Approx
Surfacing: 1.5m from the extents of the equipment with a critical fall height in excess of 940mm

IMPORTANT: you must specify the colour option you require at the time of order if it is different from the colour listed/shown above, requirements are subject to availability at the time of order